

Instructions to candidates

Duration: 02 hours

Number of questions: 06

Answer only four (04) questions

1.

- a. Determine the force in each member of the truss shown in Figure Q1 (a). Indicate whether each member is in tension or compression. (12 marks)

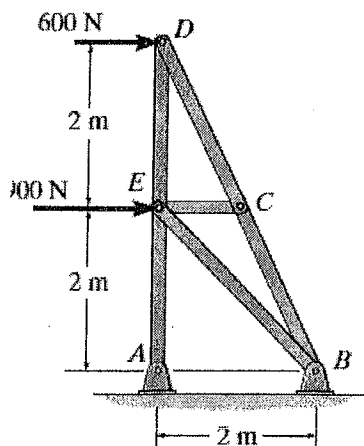

Figure Q1(a)

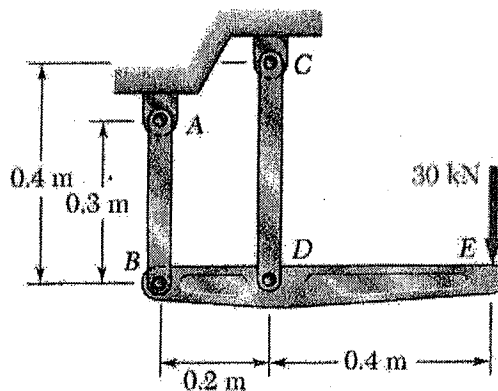
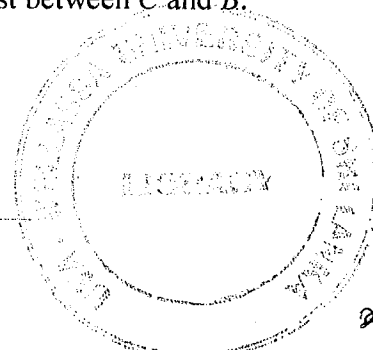

Figure Q1(b)

- b. The rigid bar *BDE* shown in Figure Q1(b) is supported by two links *AB* and *CD*. Link *AB* is made of aluminum ($E = 70 \text{ GPa}$) and has a cross-sectional area of 500 mm^2 . Link *CD* is made of steel ($E = 200 \text{ GPa}$) and has a cross-sectional area of 600 mm^2 . For the 30 kN force shown, determine the deflection of points *E* and *D*. (13 marks)

2.

- a. The torques shown in Figure Q2(a) are exerted on pulleys *B*, *C*, and *D*. If the entire shaft is made of aluminum ($G = 27 \text{ GPa}$), determine the angle of twist between *C* and *B*.



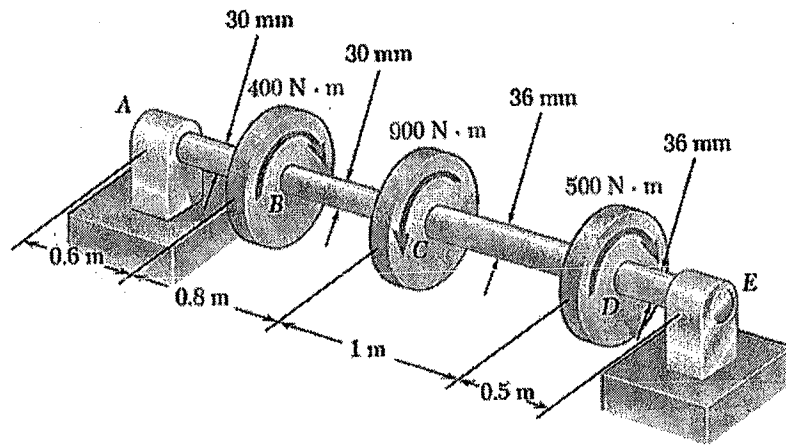

Figure Q2(a)

(12 marks)

- b. Ends A and D of the two solid steel shafts AB and CD are fixed, while ends B and C are connected to gears as shown Figure Q2(b). If a 4 kNm torque T is applied to gear B , determine the maximum shearing stress in shaft CD .

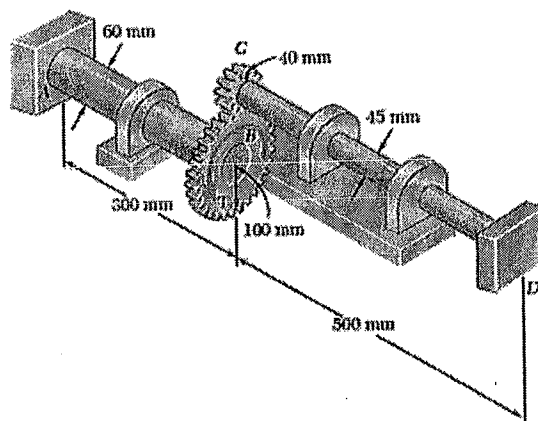

Figure Q2 (b)

(13 marks)

3.

- a. Cross-section of a beam is shown in Figure 3(a). Find,
- location of the neutral axis for bending in longitudinal direction, (7 marks)
 - second moment of area about the neutral axis. (8 marks)
- a. If the allowable stress in section ABD shown in Figure Q3(b) is 70 MPa , determine the largest force P that can be applied to the bracket shown. (10 marks)

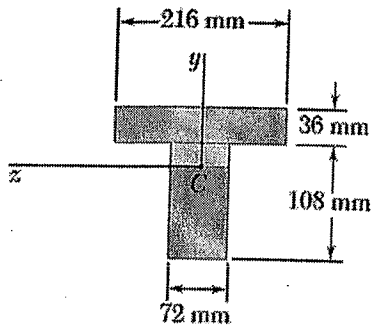

Figure Q3(a)

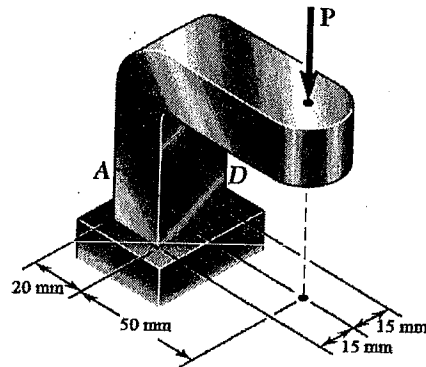

Figure Q3(b)

4. Draw the shear force and bending moment diagrams for the rectangular beam and loading shown in Figure 4(a). Hence, determine the maximum normal stress due to bending on a transverse section at C. The cross-section of the beam is shown in Figure Q 4(b).

(25 marks)

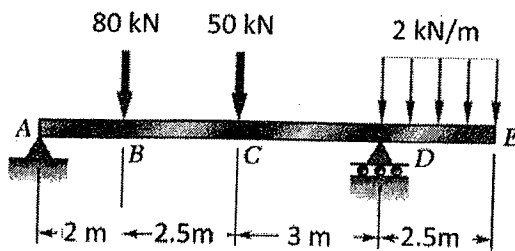

Figure Q4(a)

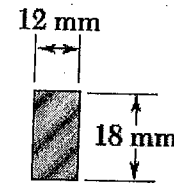
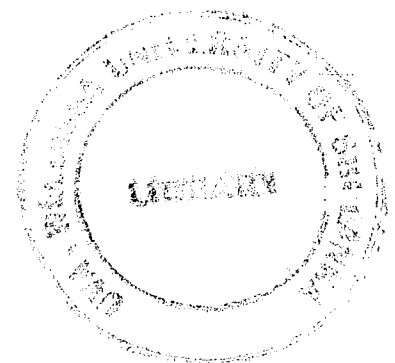

Figure Q4(b)

5. Construct the Mohr's circle for the given state of stress shown in Figure Q5. Hence determine,

- the principal stresses, (7 marks)
- the principal planes, (6 marks)
- maximum shear stress, (6 marks)
- plane at which the maximum shear occurs. (6 marks)



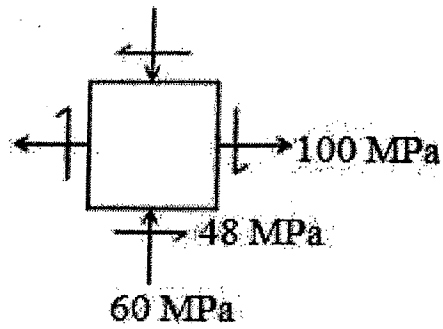

Figure Q5

6. A mechanic uses a crowfoot wrench to loosen a bolt at E as shown in Figure Q6. If the mechanic applies a vertical 100 N force at A , determine the principal stresses and the maximum shearing stress at point H located on top of the 20 mm diameter shaft.

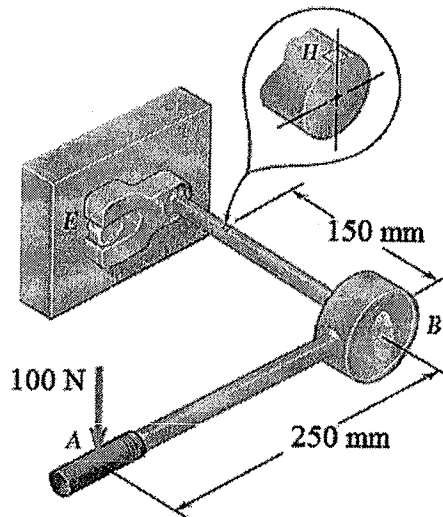

Figure Q6

(25 marks)