

Uva Wellassa University of Sri Lanka  
Faculty of Science and Technology  
Mineral Resources and Technology Degree Program  
2<sup>nd</sup> Year 1<sup>st</sup> Semester Examination – August/September 2014



**MRT 213-2 – Mineralogy and Petrology – II**

Number of questions : Four (04)

Answer **all** questions

Time allocation: Two (02) hours

Mark allocation: 400 marks

Illustrate your answers with sketches/diagrams where necessary

1.

a. Briefly explain following terms

- i. Relief
- ii. Double refraction
- iii. Isotropic minerals
- iv. Anisotropic minerals
- v. Retardation
- vi. Birefringence
- vii. Pleochroism
- viii. Optic axis of a mineral

(5×8 = 40 marks)

b. Answer following questions based on the given optical orientation diagram

$$\alpha = 1.599-1.688$$

$$\beta = 1.612-1.697$$

$$\gamma = 1.622-1.705$$

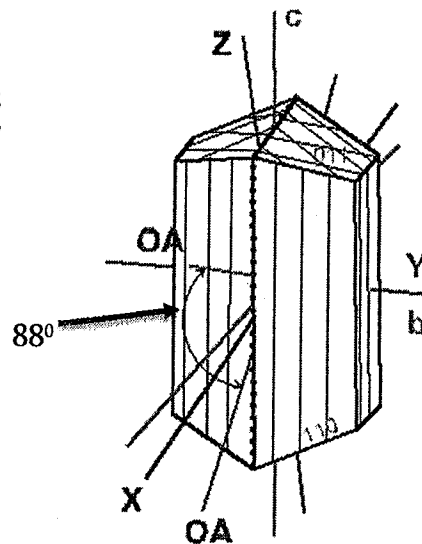

- i. What is the crystal system the mineral belongs to?
- ii. What is the optic sign of the mineral?
- iii. What is the maximum birefringence of the mineral?
- iv. What is the 2V angle?

(5×4 = 20 marks)

c. Explain the procedure of making a petrographic thin section for petrological studies. (40 marks)

2.

a. Explain how you would differentiate following mineral pairs using their optical properties.

- i. Garnet and magnetite
- ii. Biotite and olivine
- iii. Enstatite and augite
- iv. Labradorite and microcline
- v. Diopside and Hornblende
- vi. Plagioclase and Calcite

(5×6 = 30 marks)

b. Describe a method that can be used to estimate the 2V angle of a biaxial mineral. (20 marks)

c. Describe in a method to estimate the refractive index of a mineral. (20 marks)

d. Explain how you would name the rock type based on thin section studies. (30 marks)

3.

a. Describe the rock cycle. (15 marks)

b. Summarize the Bowen's reaction series. (15 marks)

c. List all the criteria that can be used to identify sedimentary rocks. (15 marks)

d. Explain the metamorphic agents. (15 marks)

e. Write short notes on following.

- i. Wentworth classification of sedimentary rocks
- ii. Stretching lineation
- iii. Factors controlling the viscosity of magmas
- iv. Formation of porphyritic texture.

(10×4 = 40 marks)

4. Compare and contrast following.

- a. Extrusive rocks and intrusive rocks
- b. Slate and gneiss
- c. Tuff and pumice
- d. Granite and basalt
- e. Sandstones and quartzite
- f. Sandstone and limestone
- g. Augen gneiss and mylonite
- h. Conglomerate and breccia
- i. Marble and dolomite
- j. Regional and contact metamorphism

(10×10=100 marks)