

Uva Wellassa University, Sri Lanka
 End Semester Examination – August 2010
 AAS 104-0
 Mathematics for Biological Sciences



Time: Two (02) hours

Total 04 Questions
 Answer all questions
 Calculators are **not** allowed

1. (a) i. Write down an algebraic expression which is not a polynomial.
 ii. Write down a trinomial of degree 5.

[4 marks]

- (b) A plastic water pipe with a hollow center is 100 inches long, 1 inch thick, and has an inner radius of x inches (see the figure given bellow).
 Write an algebraic expression in terms of x that represents the volume of the plastic used to construct the pipe and **simplify** the expression.

[Recall: The volume V of a right circular cylinder of radius r and height h is given by $V = \pi r^2 h$]

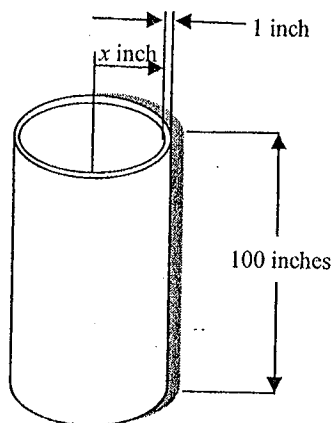

[6 marks]

- (c) Factor each of the following completely relative to the integers:
 i. $6x^4 - 8x^3 - 2x^2$ ii. $5x(x + 1) - 3(x + 1)$
 iii. $10x^3y + 20x^2y^2 - 15xy^3$

[6 marks]

- (d) Simplify each of the following:

i. $\frac{3x+8}{4x^2} - \frac{2x-1}{x^3} - \frac{5}{8x}$

ii. $\frac{3x^2+x-2}{3x^2-2x} \div (3x^2 + 5x + 2)$

iii. $\frac{\frac{x-2+y}{y} - \frac{y}{x}}{\frac{x-y}{y-x}}$

[6 marks]

- (e) It takes 8.75 hours for a private airplane to make the 2,100-mile flight from Atlanta to Los Angeles and 5 hours to make the return trip. Assuming that the wind blows at a constant rate from Los Angeles to Atlanta, **find** the airspeed of the plane and the wind rate.

[6 marks]

[P.T.O.]

2. (a) Define the terms **domain** and the **range** of the function $f(x)$.

[4 marks]

(b) Determine whether each of the following is function for the domain of all real numbers:

i. $f(x) = x^2 - 4$ ii. $h(z) = \sqrt{4z - 7}$

[4 marks]

(c) A rancher has 20 miles of fencing to fence a rectangular piece of grazing land along a straight river. If no fence is required along the river and the sides perpendicular to the river are x miles long, **find** a formula for the area $A(x)$ of the rectangle in terms of x . From practical considerations, **what** is the domain of the function A ?

[6 marks]

(d) Determine whether f is a one-to-one function for:

i. $f(x) = x^2$ ii. $f(x) = 2x - 1$

[4 marks]

(e) Find $f \circ g$ and $g \circ f$, where $f(x) = \sqrt{x + 1}$, $g(x) = \sqrt{24 + 2x - x^2}$.

[4 marks]

3. (a) Find the following limits if they exist, if not justify:

i. $\lim_{x \rightarrow -2} \frac{x^3 + 8}{x^2 - 4}$

ii. $\lim_{t \rightarrow -4} \frac{\frac{1}{4} + \frac{1}{t}}{4 + t}$

iii. $\lim_{x \rightarrow 0} \frac{1 - \sqrt{1 - 4x^2}}{x^2}$

iv. $\lim_{z \rightarrow 4} \frac{\sqrt{1 + \sqrt{z}}}{z^2 - 4}$

[8 marks]

(b) Differentiate each of the following functions with respect to the given variables:

i. $f(x) = (x^2 + 2x - 6)(3x - 2)(x^2 + 5)$ ii. $g(t) = \frac{1 - t^2}{1 + t^2}$

iii. $h(z) = \frac{\tan z}{\sin z}$; $\sin z \neq 0$

iv. $f(\phi) = 5 \sin^2 \phi - \sec \phi + e^\phi \ln \phi$

[8 marks]

(c) A spherical hot air balloon is being filled with air. The volume is changing at a rate of 2 cubic feet per minute.

How is the radius changing with respect to time when the radius is equal to 2 feet?

[4 marks]

(d) A box manufacturer desires to create a box with a surface area of 100 inches squared. What is the maximum size volume that can be formed by bending this material into a box? The box is to be closed. The box is to have a square base and rectangular sides.

[4 marks]

4. (a) Integrate each of the following functions:

i. $\int (x^2 - 3x + 5) dx$ ii. $\int (t^2 + t^{-2}) dt$ iii. $\int \sqrt{y}(1 - y^2) dy$

iv. $\int (e^x - \sec x \tan x + x^{-3}) dx$ v. $\int \frac{4x^3 - 2x^2 + 5x - 2}{x^2} dx; x \neq 0$

[10 marks]

(b) Evaluate each of the following integrals:

i. $\int_1^2 \frac{2w^5 - w + 3}{w^2} dw; w \neq 0$ ii. $\int_1^3 (x^4 - 3x^2 + 3) dx$

iii. $\int_0^{\frac{1}{2}} (8t^3 + 6t^2 - 5t + 3) dt$ iv. $\int_0^{\pi/2} (3 \sin \theta + \sec^2 \theta - 5) d\theta$

v. $\int_{-\pi/12}^{-\pi/12} [e \sin 2x + \cos^2 5x - \ln(\sec x) + e^{5x} \tan^5 3x] dx$

[10 marks]

(c) Compute the area of the region S between the graphs f and g over the interval $[0, 2]$, where $f(x) = x(x - 2)$ and $g(x) = x/2$.

[6 marks]

