

Uva Wellassa University of Sri Lanka
Faculty of Science and Technology
Department of Science and Technology
300 Level 2nd Semester Examination – December 2018/January 2019
SCT 372-2 Computer Aided Design & Manufacturing

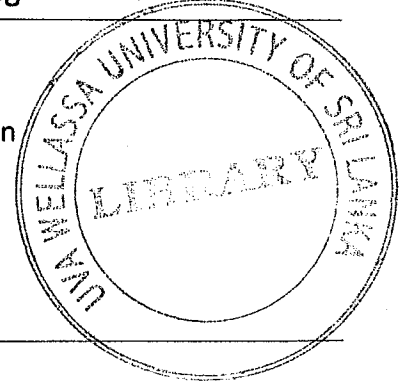
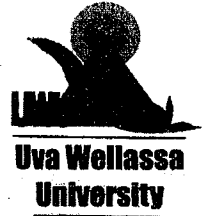

Instructions to candidates

Duration: Two (02) hours

Number of questions: Two(02) essay questions and One(01) Practical question

Mark allocation: 100

Answer all questions

All dimensions are in mm.

Computers will be provided with the relevant software.

1.
 - a. Compare the terms CAD and CAM. State advantages of using CAD/CAM in industrial designs. (10 mark)
 - b. State five usages of CAD/CAM in the industry. (7.5 mark)
 - c. State four elements of CIM system. (7.5 mark)

2.
 - a. Explain the process of Rapid Prototyping and describe how it benefit for industrial designs. (08 mark)
 - b. State steps of engineering design process. (05 mark)
 - c. Write the G-Code program for the following part shown in Figure 01 considering the points given in below.
 - a. Use the given point as the part coordinate zero point
 - b. The thickness of the part is 10 mm and you have given 10 mm metal sheet to cut the part
 - c. Only one run is needed to cut a line
 - d. Use an absolute coordinate system
 - e. Use 6 mm end mill cutter and 10 mm Drill bit
 - f. Refer G-Codes at the end of the exam paper
 - g. Use Cutter compensation G41, G42 accordingly

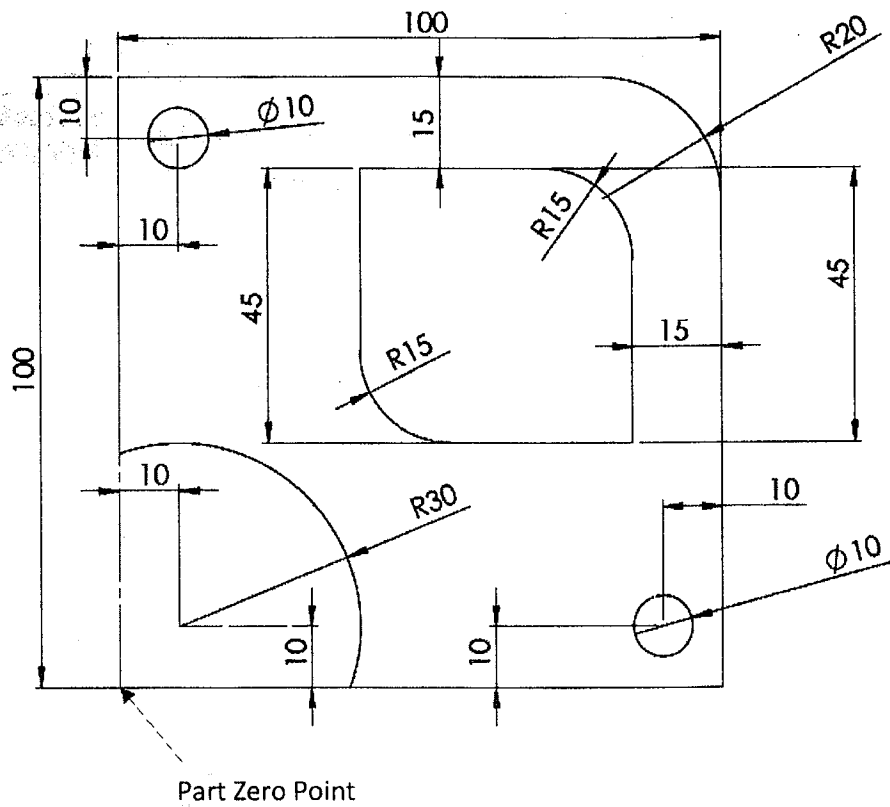

Figure 01

(12 mark)

3.

Figure 02 shows a mold of a plastic funnel. You are requested to design appropriate CNC machining operation sequence for **one of the mold part** in Figure 03 named "Bottom part" using "SolidCAM" software. Define rectangular stock material of 10 mm on all sides. Use appropriate part coordinate systems. The part file is located in your common folder.

(50 marks)

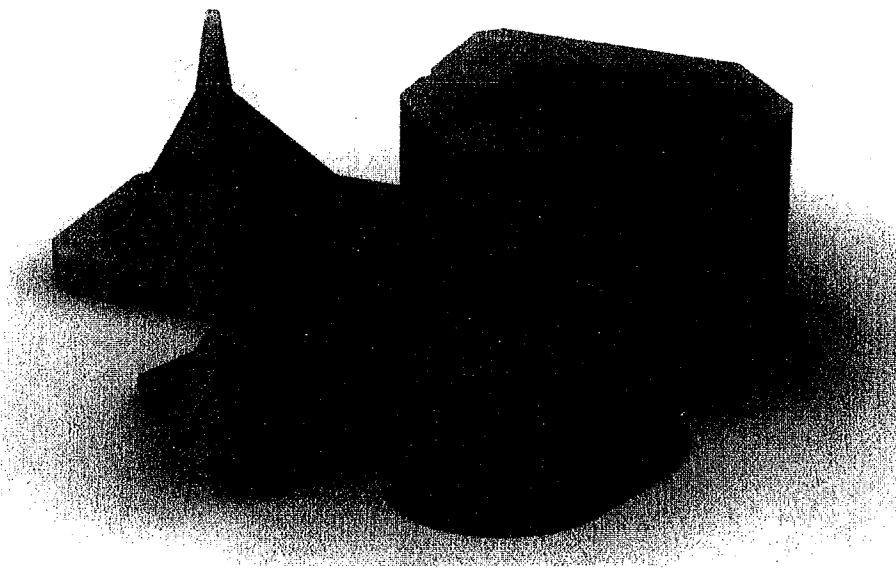

Figure 02

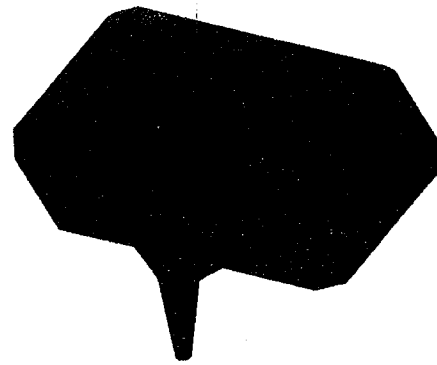
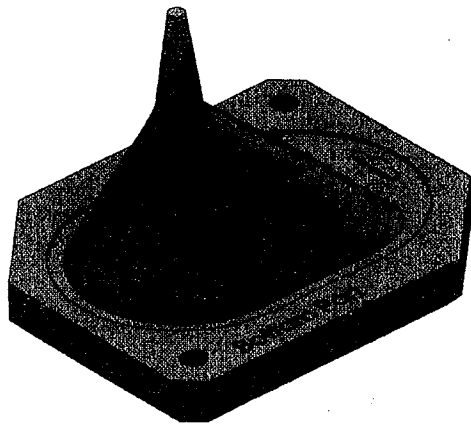

Figure 03

- G00 - Positioning at rapid speed; Mill and Lathe
- G01 - Linear interpolation (machining a straight line); Mill and Lathe
- G02 - Circular interpolation clockwise (machining arcs); Mill and Lathe
- G03 - Circular interpolation, counter clockwise; Mill and Lathe
- G04 - Mill and Lathe, Dwell
- G09 - Mill and Lathe, Exact stop
- G10 - Setting offsets in the program; Mill and Lathe
- G12 - Circular pocket milling, clockwise; Mill
- G13 - Circular pocket milling, counterclockwise; Mill
- G17 - X-Y plane for arc machining; Mill and Lathe with live tooling
- G18 - Z-X plane for arc machining; Mill and Lathe with live tooling
- G19 - Z-Y plane for arc machining; Mill and Lathe with live tooling
- G20 - Inch units; Mill and Lathe
- G21 - Metric units; Mill and Lathe
- G27 - Reference return check; Mill and Lathe
- G28 - Automatic return through reference point; Mill and Lathe
- G29 - Move to location through reference point; Mill and Lathe (slightly different for each machine)
- G31 - Skip function; Mill and Lathe
- G32 - Thread cutting; Lathe
- G33 - Thread cutting; Mill
- G40 - Cancel diameter offset; Mill. Cancel tool nose offset; Lathe
- G41 - Cutter compensation left; Mill. Tool nose radius compensation left; Lathe
- G42 - Cutter compensation right; Mill. Tool nose radius compensation right; Lathe
- G43 - Tool length compensation; Mill
- G44 - Tool length compensation cancel; Mill (sometimes G49)
- G50 - Set coordinate system and maximum RPM; Lathe
- G52 - Local coordinate system setting; Mill and Lathe
- G53 - Machine coordinate system setting; Mill and Lathe
- G54~G59 - Workpiece coordinate system settings #1 to #6; Mill and Lathe
- G61 - Exact stop check; Mill and Lathe
- G65 - Custom macro call; Mill and Lathe
- G70 - Finish cycle; Lathe
- G71 - Rough turning cycle; Lathe
- G72 - Rough facing cycle; Lathe
- G73 - Irregular rough turning cycle; Lathe
- G73 - Chip break drilling cycle; Mill



G74 - Left hand tapping; Mill
 G74 - Face grooving or chip break drilling; Lathe
 G75 - OD groove pecking; Lathe
 G76 - Fine boring cycle; Mill
 G76 - Threading cycle; Lathe
 G80 - Cancel cycles; Mill and Lathe
 G81 - Drill cycle; Mill and Lathe
 G82 - Drill cycle with dwell; Mill
 G83 - Peck drilling cycle; Mill
 G84 - Tapping cycle; Mill and Lathe
 G85 - Bore in, bore out; Mill and Lathe
 G86 - Bore in, rapid out; Mill and Lathe
 G87 - Back boring cycle; Mill
 G90 - Absolute programming
 G91 - Incremental programming
 G92 - Reposition origin point; Mill
 G92 - Thread cutting cycle; Lathe
 G94 - Per minute feed; Mill
 G95 - Per revolution feed; Mill
 G96 - Constant surface speed control; Lathe
 G97 - Constant surface speed cancel
 G98 - Per minute feed; Lathe
 G99 - Per revolution feed; Lathe

A	A-axis command (usually a rotary)
B	B-axis command (usually a rotary)
C	C-axis command (usually a rotary)
D	Tool diameter/radius compensation number
F	Feedrate value
G	CNC function or code
H	Tool length compensation number
I	Circle center distance for X
J	Circle center distance for Y
K	Circle center distance for Z or circle radius (G12/G13)
L	Loop count for subroutine/macro
M	Machine function or code
N	Block sequence number
P	Macro programming variable
Q	Subroutine program number to call
R	Rotation or scaling factor
S	Spindle speed (RPM)
T	Tool number or turret position
X	X-axis command (usually a linear)
Y	Y-axis command (usually a linear)
Z	Z-axis command (usually a linear)

CNC M Codes

M00 - Program stop; Mill and Lathe
 M01 - Optional program stop; Lathe and Mill
 M02 - Program end; Lathe and Mill
 M03 - Spindle on clockwise; Lathe and Mill
 M04 - Spindle on counterclockwise; Lathe and Mill
 M05 - Spindle off; Lathe and Mill
 M06 - Toolchange; Mill
 M08 - Coolant on; Lathe and Mill
 M09 - Coolant off; Lathe and Mill
 M10 - Chuck or rotary table clamp; Lathe and Mill
 M11 - Chuck or rotary table clamp off; Lathe and Mill
 M19 - Orient spindle; Lathe and Mill
 M30 - Program end, return to start; Lathe and Mill
 M97 - Local sub-routine call; Lathe and Mill
 M98 - Sub-program call; Lathe and Mill
 M99 - End of sub program; Lathe and Mill