

**Instructions to candidates**

Duration: 02 hours

Number of questions: 04

Answer all questions

1.

- a. Two solid cylindrical rods  $AB$  and  $BC$  are welded together at  $B$  and loaded as shown in Figure 1(a). If  $d_1 = 40$  mm and  $d_2 = 20$  mm, find the average normal stress at the midsection of
  - i. rod  $AB$
  - ii. rod  $BC$
  
- b. The rigid member  $BC$  is supported by the links  $AB$  and  $CD$  as shown in Figure 1(b). Each of the links  $AB$  and  $CD$  is made of aluminum ( $E = 68.9$  GPa and has a cross-sectional area of  $130$  mm<sup>2</sup>). Determine the deflection of point  $E$ .

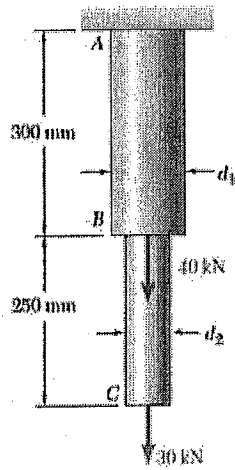

Figure 1(a)

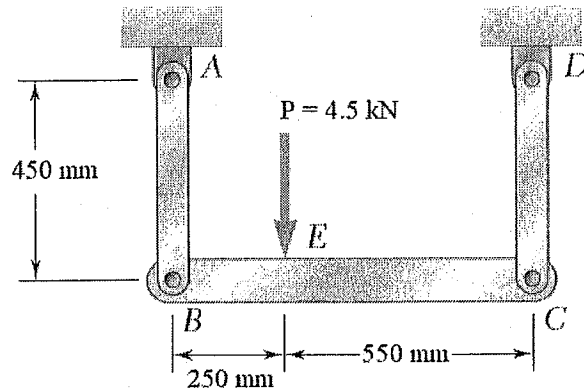

Figure 1(b)

2.

- a. For the solid steel shaft shown in Figure 2(a) where  $G = 77 \text{ GPa}$ ,
  - i. determine the angle of twist at A.
  - ii. If the steel shaft is hollow with a 30 mm outer diameter and a 20 mm inner diameter, determine the angle of twist at A.
- b. A torque of magnitude  $T = 100 \text{ Nm}$  is applied to shaft AB of the gear train shown in Figure 2(b). The diameters of the three solid shafts are,  $d_{AB} = 21 \text{ mm}$ ,  $d_{CD} = 30 \text{ mm}$ , and  $d_{EF} = 40 \text{ mm}$ . Determine the maximum shearing stress in
  - i. shaft AB
  - ii. shaft EF

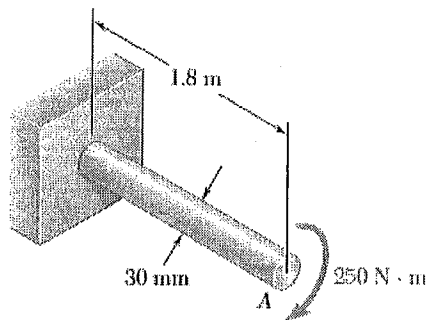

Figure 2(a)

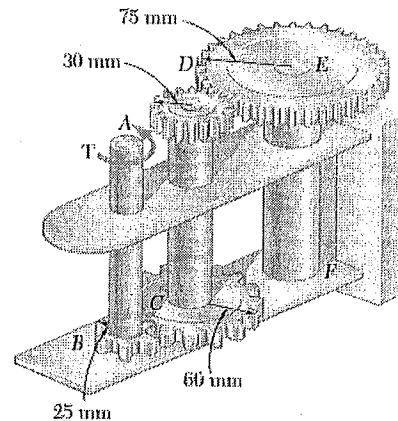

Figure 2(b)

3. Construct the bending moment diagram and shear force diagram for the simply supported beam shown in Figure 3(a). Hence, determine the maximum tensile stress and maximum compressive stress due to the point load P. The cross section of the beam is shown in Figure 3(b). Data are as follows:  $P = 5.4 \text{ kN}$ ,  $L = 3.0 \text{ m}$ ,  $d = 1.2 \text{ m}$ ,  $b = 75 \text{ mm}$ ,  $t = 25 \text{ mm}$ ,  $h = 100 \text{ mm}$ , and  $h_1 = 75 \text{ mm}$ .

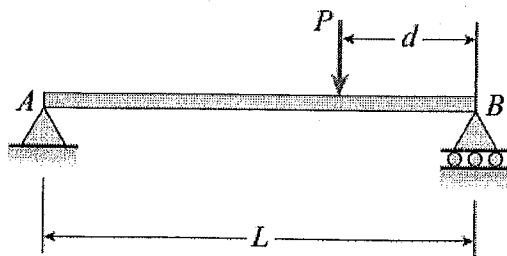

Figure 3(a)

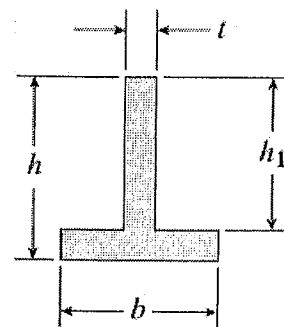

Figure 3(b)

4. Forces are applied at points  $A$  and  $B$  of the solid cast-iron bracket shown in Figure 4. The diameter of the bracket is 20 mm. Determine the principal stresses and the maximum shearing stress at
- point  $H$
  - point  $K$

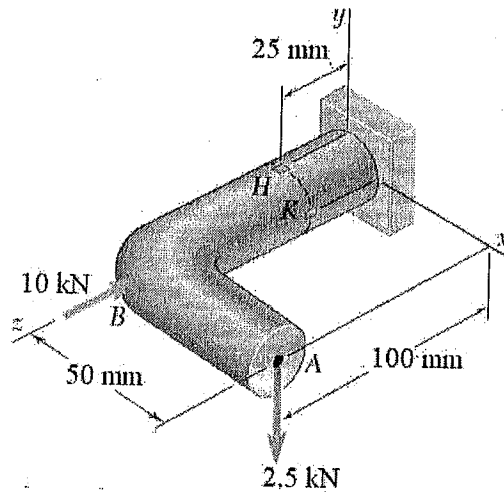

Figure 4

