

Uva Wellassa University of Sri Lanka
Faculty of Science and Technology
Department of Computer Science and Technology
200 level 1st Semester Examination – Jul./ Aug. 2016
CST241-3 Data Communication and Networking



Instructions to candidates

Duration: Three (03) hours

Number of questions: Six (06) Essay questions

Answer all the questions.

Mark allocation: 100

1.
 - a. Briefly explain the TCP/IP model and how it differs from OSI model. (4 mark)
 - b. Explain the process of data flow between two devices by using OSI model. (5 mark)
 - c. List the protocols used in different layers of OSI model. (3 mark)
 - d. Explain transport layer protocols of OSI model in details. (4 mark)

2.
 - a. Write three (03) IP address classes and its' characteristics. (4 mark)
 - b. Use the following network address and subnet mask to answer following questions.
network address – 198.168.30.0
Subnet mask – 255.255.255.224
 - i. What is the class of the above network address? (1 mark)
 - ii. Calculate the number of subnetworks using the subnet mask. (3 mark)
 - iii. Calculate the number of hosts per network. (2 mark)
 - iv. Specify the first and last IP addresses of first IP range. (2 mark)
 - v. What is the broadcast IP address of the first IP address range? (2 mark)
 - c. Specify the differences between IPv4 and IPv6? (5 mark)

3.
 - a. Write short notes for **two (02)** topics mentioned below.
 - i. Public Switch Telephone Network (PSTN)
 - ii. Mechanism of light propagation in fiber optics
 - iii. Guided transmission media Vs. unguided transmission media
 - iv. Physical topologies (2 x 3 mark)
 - b. Briefly explain the theoretical basis behind the data transmission. (4 mark)
 - c. Describe three (03) types of guided media with the connector types and applications. (3 mark)
 - d. Why wireless networking is important in LANs? (2 mark)

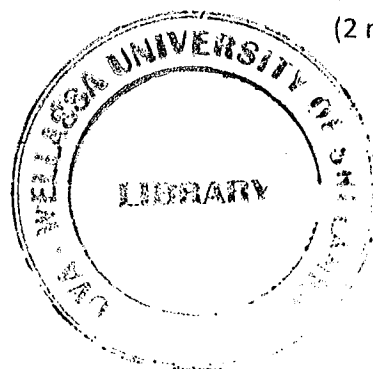

4.

- a. Distinguish between error detection and error correction in data communication. (2 mark)
- b. List the four(04) error detection techniques and explain **one(01)** of those techniques. (4 mark)
- c. Suppose you want to transmit the data 100111001. The divisor is 1001001.
What bit string is actually sent to the receiver? (Hint: use *Cyclic redundancy check*) (5 mark)
- d. Explain two(02) error correction techniques using relevant examples. (4 mark)

5.

- a. Why congestion arises in packet-switched network? (3 mark)
- b. Briefly describe the relevant policies in 'open loop congestion control'. (6 mark)
- c. Compare and contrast the Leaky Bucket and Token Bucket algorithms. (5 mark)
- d. Explain the 'Load Shedding' technique in close loop congestion control. (6 mark)

6.

- a. Explain Dijkstra's shortest path routing algorithm with an example. (3 mark)
- b. Differentiate Dijkstra's shortest path routing algorithm with distance-vector routing algorithm. (4 mark)
- c. Consider the network graph shown in Figure 1.
 - i. Show the operation of Dijkstra's (Link State) algorithm for computing the least cost path from B to all destinations. (6 mark)
 - ii. Briefly describe how to determine the shortest path from B to D from the results in part (i). (2 mark)

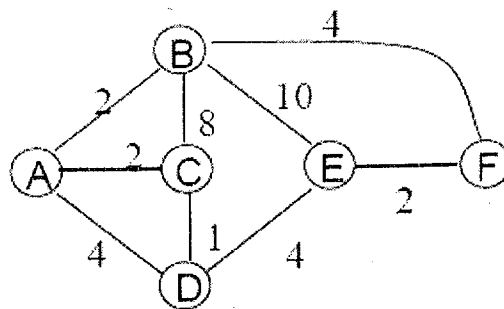

Figure 1 : network graph