

Uva Wellassa University, Sri Lanka
End Semester Examination – July 2010
SCT 366-2 Mechanics of Machines



Time: Two (02) hours

Total 06 Questions.

Answer four (04) questions only.

1. A mechanism, as shown in Fig.Q01, has the following dimensions:

OA = 200 mm; AB = 1.5 m; BC = 600 mm; CD = 500 mm and BE = 400 mm.

1.1. Locate all the instantaneous centres.

(10 marks)

1.2. If crank OA rotates uniformly at 120 r.p.m. clockwise, write expressions to find velocities of B, C and D.

(07 marks)

1.3. Write expressions for angular velocities of links AB, BC and CD.

(08 marks)

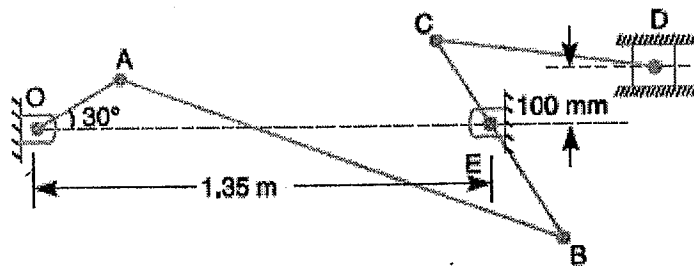

Fig.Q01

2. In Fig.Q02, the angular velocity of the crank OA is 600 r.p.m. Sketch the velocity diagram and write expressions for the linear velocity of the slider D and the angular velocity of the link BD, when the crank is inclined at an angle of 75° to the vertical. The dimensions of various links are: OA = 28 mm; AB = 44 mm; BC 49 mm; and BD = 46 mm. The centre distance between the centres of rotation O and C is 65 mm. The path of travel of the slider is 11 mm below the fixed point C. The slider moves along a horizontal path and OC is vertical.

(25 marks)

4. In the mechanism, as shown in Fig.Q04, the crank OA rotates at 20 r.p.m. anticlockwise and gives motion to the sliding blocks B and D. The dimensions of the various links are OA = 300 mm; AB = 1200 mm; BC = 450 mm and CD = 450 mm. For the given configuration,

4.1. Sketch the velocity diagram.

(04 marks)

4.2. Sketch the acceleration diagram.

(05 marks)

4.3. Write expressions to determine velocities of sliding at B and D.

(04 marks)

4.4. Write expressions to determine the angular velocity of CD.

(04 marks)

4.5. Write expressions to determine the linear acceleration of D.

(04 marks)

4.6. Write expressions to determine angular acceleration of CD.

(04 marks)

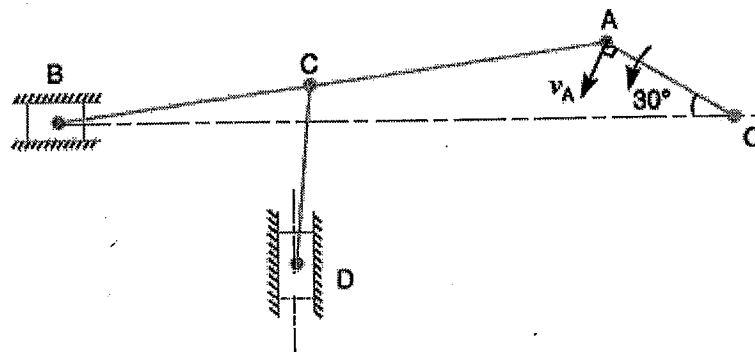

Fig.Q04

5. The driving crank AB of the quick-return mechanism, as shown in Fig.Q05, revolves at a uniform speed of 200 r.p.m. Draw velocity and acceleration diagrams. Write expressions to find the velocity and acceleration of the tool-box R, in the position shown, when the crank makes an angle of 60° with the vertical line of centres PA. Write expressions to find the acceleration of sliding of the block at B along the slotted lever PQ.

(25 marks)

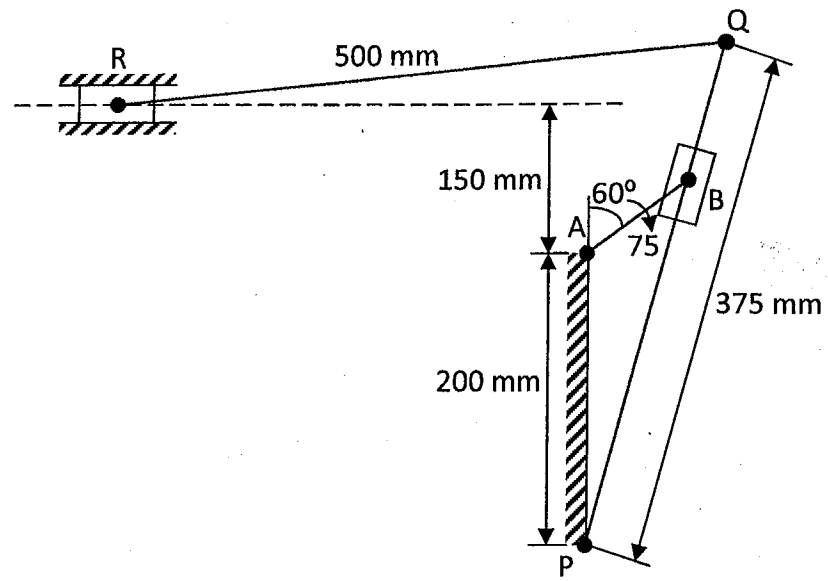

Fig.Q05

6. A single cylinder, single acting, four stroke gas engine develops 20 kW at 300 r.p.m. The work done by the gases during the expansion stroke is three times the work done on the gases during the compression stroke, the work done during the suction and exhaust strokes being negligible. If the total fluctuation of speed is not to exceed ± 2 per cent of the mean speed and the turning moment diagram during compression and expansion is assumed to be triangular in shape, find the moment of inertia of the flywheel.

(25 marks)