

SCT 464-2 Power Electronics

Instructions to candidate

Number of questions: Four (04)

Answer all questions

Time allocation: Two (02) hours

Total marks allocated: 100

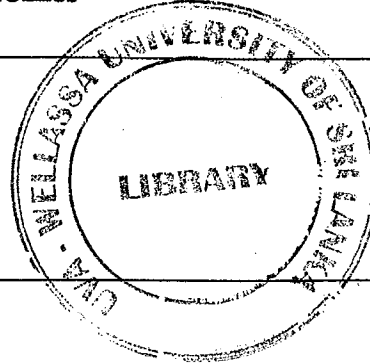

1.
 - a. Name six (06) types of thyristors. (03 marks)
 - b. Briefly explain two (02) types of thyristor-trigger circuits. (04 marks)
 - c. What are the methods that could turn off a Silicon Controlled Rectifier (SCR)? Briefly explain. (05 marks)
 - d. Briefly explain five (05) different ways that a thyristor can be damaged. State the protection measures that can be taken to avoid such damage. (05 marks)
 - e. Compare Silicon Controlled Rectifier over Triacs. Draw the current - voltage relationship of both devices. (08 marks)
2.
 - a. Name one (01) step up chopper used in electronics. Draw the circuit diagram with ideal components and explain its operation. (04 marks)
 - b. Derive the equation for the relationship between input voltage and output voltage for the above step up chopper in Continuous Conduction Mode. (05 marks)

c. When the above step up chopper is in Continuous Conduction Mode at steady-state, draw the waveforms of following parameters.

- i. voltage across the inductor
- ii. output current
- iii. inductor current
- iv. capacitor current

(04 marks)

d. A buck regulator has an input voltage of $V_{in} = 12\text{ V}$. The required average output voltage is $V_{out} = 5\text{ V}$ at $R = 500\ \Omega$. The peak to peak output ripple voltage is 20 mV . The switching frequency is 25 kHz . If the peak to peak ripple current of the inductor is 0.8 A determine the following.

- i. The duty cycle (D)
- ii. The filter inductance (L)
- iii. The filter capacitance (C)

(12 marks)

3.

a. Fig. Q3.1 shows a full bridge rectifier. Draw the following waveforms.

- i. voltage across the load
- ii. current flowing through the load
- iii. voltage across D2 diode

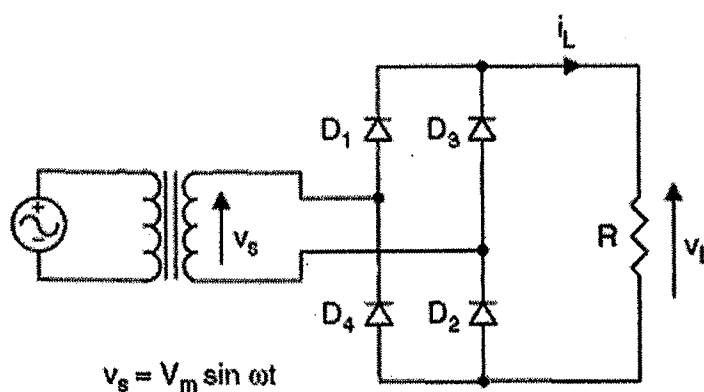

Fig. Q3.1

(03 marks)

b. Explain the functionality of D_1 diode as shown in Fig. Q3.2.

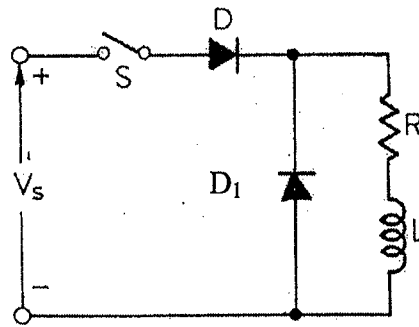

Fig. Q3.2



(03 marks)

c. Describe the following terms related to rectifiers.

- i. Rectification ratio
- ii. Form factor
- iii. Ripple factor
- iv. Transformer utilization factor

(1.5 x 04)

d. Draw the circuit diagram of a flyback converter and explain its operation when the transistor's switch is on and off.

(05 marks)

e. Derive the relationship between input voltage (V_{in}) and output voltage (V_{out}) for the above converter at steady state.

(03 marks)

f. The average output voltage of a flyback converter $V_{out} = 24$ V and the switching frequency is 1 kHz. The duty cycle ratio is 50%. Find the peak to peak ripple current (ΔI_M) across the 2 mH primary magnetizing inductor. The turns ratio of the transformer is 0.25.

(05 marks)

4.

a. Explain variable DC link type inverters and fixed DC link type inverters.

(04 mark)

b.

i. Draw the fundamental, 3rd and 5th harmonics of a simple square wave output inverter.

(06 marks)

- ii. Using a block diagram briefly explain the method used to eliminate the noise in the output signal of a simple square wave output inverter. (03 marks)
- c. Explain a type of modulation technique used in inverters. (04 marks)
- d. Draw a half bridge single phase voltage source inverter and explain its functionality using suitable tables. (04 marks)
- e. Explain bipolar modulation of full bridge single phase voltage source inverter. (04 marks)