

Uva Wellassa University, Sri Lanka
End Semester Examination – August 2011
SCT 161-1 Basic Electricity & Electronics (Repeat)



Time: One (01) hour

Total 03 Questions
Answer All questions.

- 1) a. State the Thevenin's theorem for a complex network circuit.
- b. Write down the relationship between the Thevenin voltage and the Norton current.
- c. Find the Thevenin equivalent circuit across R_L of the Wheatstone bridge network given in Figure Q1.

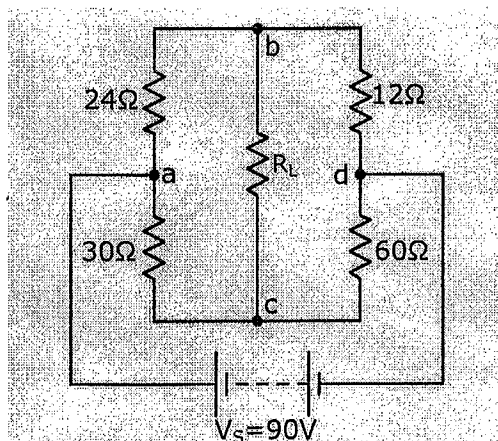

Figure Q1

(40 Marks)

- 2) a. What is the functionality of the commutator in a DC generator?
- b. Write down the EMF equation for a DC generator. State the terms denoted by the symbols of your equation.
- c. A DC generator develops an e.m.f. of 220V when driven at 1100 rpm with a flux per pole of 0.02 Wb. It is desired that this e.m.f. be increased to 240V at 1200 rpm. What should be the value of the flux per pole under the new circumstances?

(30 Marks)

- 3) a. What is the back e.m.f. of a DC motor? Derive the relation between the back e.m.f. and the supplied voltage in terms of armature resistance.
- b. A motor draws 2.5A from 120V mains and runs at a speed of 1200 rpm. The armature resistance is 0.2Ω . When the motor is loaded until its armature current is 30A, how much mechanical power is developed by the motor?

(30 Marks)