

Uva Wellassa University of Sri Lanka
Faculty of Science and Technology
Department of Computer Science and Technology
200 level 1st Semester Examination – Sept. / Oct. 2015
CST 241-3 / SCT 377-3 Data Communication and Networking



Instructions to candidates
Duration: Three (03) hours
Number of questions: Six (06)
Answer all Questions
Mark allocation: 100



- a. Explain in detail the difference between the OSI model and the TCP/IP stack and its operation at each layer (explain how the relevant headers will operate along with the asked question).
- b. Explain the difference between Segment and Frame with the aid of diagrams.
- c. Describe private address classes, IP address ranges associated and the appropriate subnet masks.
- d. Illustrate in a diagram how the OSI architecture operated in WAN. (15 mark)

Use the network address given below to answer the following questions.
Address – 192.168.4.0/24

- a. What is the network address indicated above?
- b. Illustrate the network and host portion of the address indicated above.
- c. Indicate that first usable IP address range.
- d. What is the broadcast IP address of the first usable IP address range.
- e. Make four (04) subnets from above IP address. (15 mark)

- a. List ISO-OSI seven (7) layers.
- b. Name two (2) organizations which define protocols/standards according to the ISO standards.
- c. What is meant by multiplexing?
- d. Briefly explain,
 - i. Frequency Division Multiplexing (FDM)
 - ii. Time Division Multiplexing (TDM)

e. If four (4) input channels (each channel's data rate is 100bps) are multiplexed and there is one overhead channel (25 bps) as follows, calculate the output bit rate.

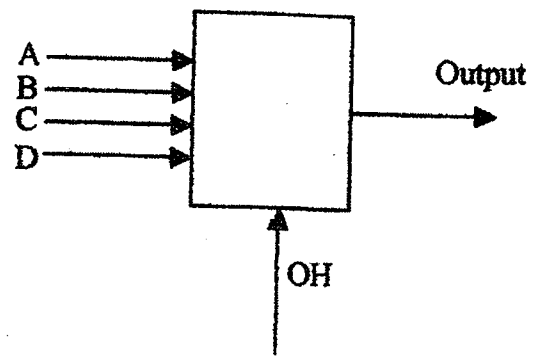

(20 mark)

4.

- a. Write brief notes on the following transmission media.
 - i. Copper cables
 - ii. Fiber optics
 - iii. Radio transmission
 Include the noise, attenuation and interference features of those transmission media in your brief note.

- b. Draw a diagram and explain the light propagation principle in fiber optics.
- c. Illustrate how light signal(s) travels in Single Mode Fiber (SMF) and Multimode Fiber (MMF) with typical core and clad diameters of SMF and MMF.
- d. Briefly explain what is "Graded index" and "Step index" fiber (15 mark)

5.

- a. Briefly explain the four (4) physical layer characteristics with examples.
- b. What are the three (3) major functions of data link layer?
- c. What are meant by "Forward Error Correction" and "Backward Error Correction"? Explain with examples.
- d. Parity check is an error detection method. If received bit pattern and the parity method used as follows, state whether there are error(s) or not. (Last bit is the parity bit)

	Received bit pattern	Parity method used
i.	1 1 1 0 0 0 1 1	Odd
ii.	1 1 1 0 0 0 1 1	Even
iii.	1 1 1 1 0 0 0 0	Odd
iv.	1 1 1 1 0 0 0 0	Even

e. Briefly explain Cyclic Redundancy Check (CRC) error detection method. State two (2) names of standard divisor values used in CRC. (15 mark)

6.

- a. What is modulation?
- b. Consider the following bit pattern for the digital modulation.
1 0 0 0 1 0 0 1 1 1 1 0
- FSK
 - ASK
 - BPSK
 - QPSK
- c. Explain what is meant by signal to noise ratio (S/N)?
- d. Describe how SNR affect to the signal quality.
- e. Automatic Repeat reQuest (ARQ) is a example for Backward Error Correction. Draw the timing diagrams for the followings,
- Send 5 frames and 3rd frame has errors. - use Idle ARQ
 - Send 6 frames and 4th frame has errors - use Selective ARQ
 - Send 6 frames and 4th frame has errors – use Go-Back-N ARQ (20 mark)

