

SCT 366-2 Mechanics of Machines

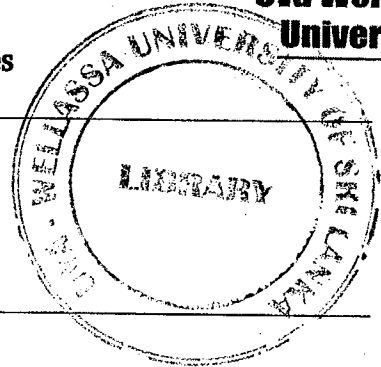

Total four (04) Questions
 Answer all questions.
 Time: Two (02) Hours
 Total mark allocation 100.

- In the mechanism shown in Figure Q1 find the instantaneous centers of the links B, C and D. If the link A rotates clockwise at 10 rad/s, write expressions to find the angular velocity of link E. The lengths of links are as follows:
 Link A = 25 mm; Link B = Link C = 100 mm; Link D = Link E = 50 mm. The link D is hinged to link B at 25 mm from the left hand end of link B.

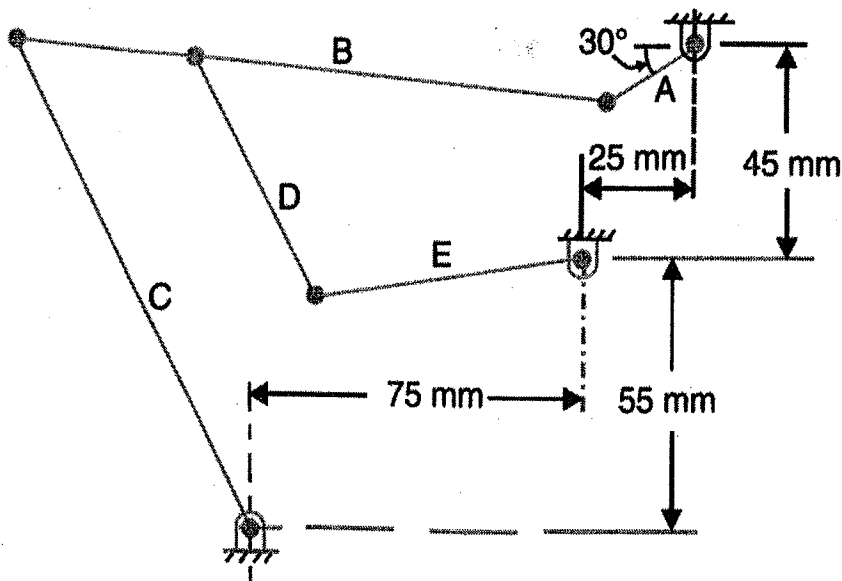

Figure Q1

(25 marks)

2. The dimensions of the links in a mechanism shown in Figure Q2 are as follows :

$AB = 30 \text{ mm}$; $BC = 80 \text{ mm}$; $CD = 45 \text{ mm}$; and $CE = 120 \text{ mm}$.

The crank AB rotates uniformly in the clockwise direction at 120 rpm. Draw the velocity diagram for the given configuration of the mechanism and write expressions to determine the velocity of the slider E and angular velocities of the links BC , CD and CE .

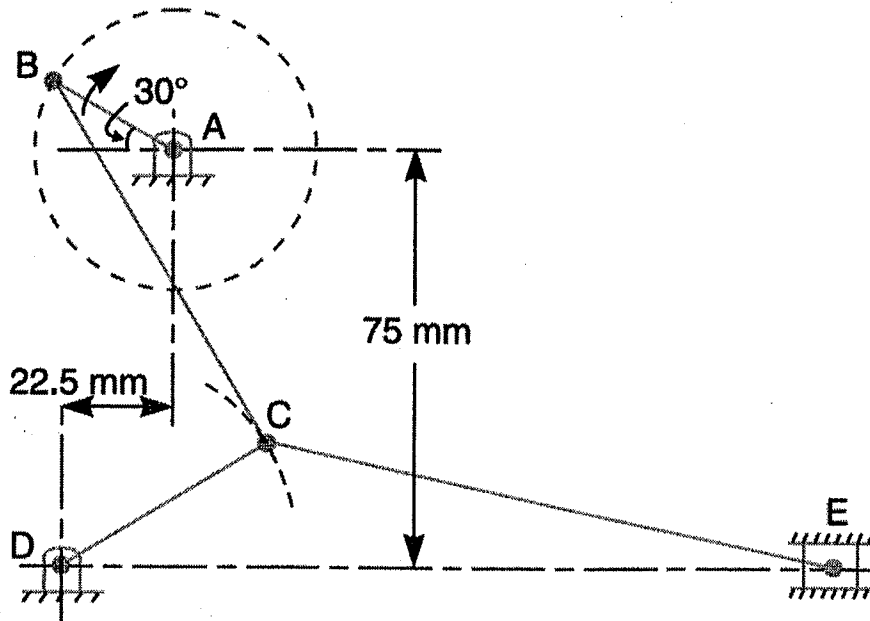

Figure Q2

(25 marks)

3. In the mechanism shown in Figure Q3, the crank OA is 100 mm long and rotates in a clockwise direction at a speed of 100 rpm.

The straight rod BCD rocks on a fixed point at C . The links $BC = CD = 200 \text{ mm}$; and the link $AB = 300 \text{ mm}$. E is a slider, which is driven by the rod $DE = 250 \text{ mm}$.

Write expressions to find the velocity and acceleration of E .

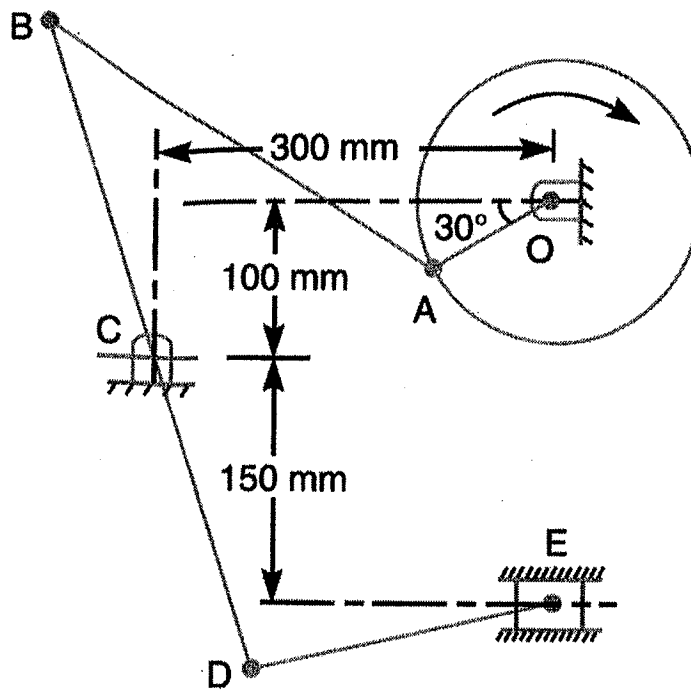

Figure Q3



(25 marks)

4. In a turning moment diagram, the areas above and below the mean torque line taken in order are 4400, 1150, 1300 and 4550 mm² respectively. The scales of the turning moment diagram are:

Turning moment, 1 mm = 100 Nm; crank angle, 1 mm = 1°.

Find the mass of the flywheel required to keep the speed between 297 and 303 rpm, if the radius of gyration is 0.525 m.

(25 marks)