

Uva Wellassa University, Sri Lanka
End Semester Examination – August / September 2011
SCT 201-2 Mathematics II (Repeat)



Time: Two (02) hours

Total three (03) questions.

Answer all questions.

Calculators are allowed.

01. a.) State elementary row operations.

(06 marks)

b.) A direct current electric circuit consisting of conductors, resistors, and batteries is diagramed in the figure.

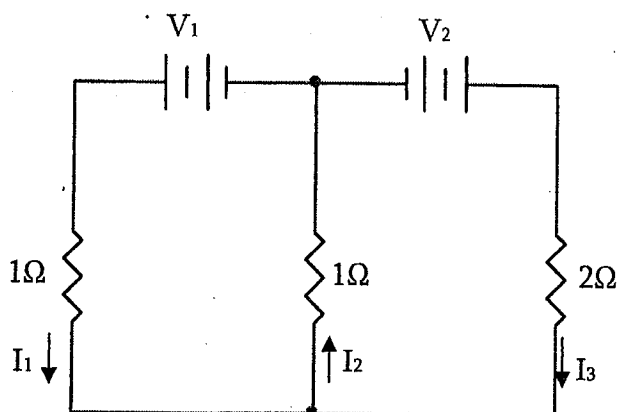

If I_1 , I_2 and I_3 are the currents in amperes in the three branches of the circuit and V_1 and V_2 are the voltages in volts of the two batteries, then Kirchhoff's laws can be used to show that the currents satisfy the following system of equations:

$$I_1 - I_2 + I_3 = 0$$

$$I_1 + I_2 = V_1$$

$$I_2 + 2I_3 = V_2$$

Solve this system for:

i.) $V_1 = 10$, $V_2 = 10$

ii.) $V_1 = 10$, $V_2 = 15$

(24 marks)

02. a.) Farmer Jane owns 45 acres of land. She is going to plant each with wheat or corn. Each acre planted with wheat yields Rs.20,000.00 profit; each with corn yields Rs.30,000.00 profit. The labor and fertilizer used for each acre are given in the following table. One hundred workers and 120 tons of fertilizer are available. Use Linear Programming to determine how Jane can maximize profits from her land.

	Wheat	Corn
Labor	3 workers	2 workers
Fertilizer	2 tons	4 tons

(15 marks)

- b.) Use the Simplex Method to solve the following Linear Programming problem.

$$\begin{aligned} \max \quad & z = x_1 + x_2 \\ \text{s.t.} \quad & 2x_1 + x_2 \leq 4 \\ & x_1 + 2x_2 \leq 3 \\ & x_1 \geq 0, \quad x_2 \geq 0 \end{aligned}$$

(15 marks)

03. a.) A tank contains 100 L of water. A solution with a salt concentration of 0.4 Kg/L is added at a rate of 5 L/min. The solution is kept mixed and is drained from the tank at a rate of 3 L/min. If $y(t)$ is the amount of salt in kilograms after t minutes, then y satisfies the differential equation,

$$\frac{dy}{dt} = 2 - \frac{3y}{100 + 2t}$$

Solve this equation and find the concentration after 20 minutes.

(30 marks)

- b.) Consider the vibrating system described by the initial value problem

$$u'' + 3u' + \frac{9}{4}u = 0 \quad ; \quad u(0) = 3 \quad \text{and} \quad u'(0) = 2$$

Find $u(t)$ for any time t .

(10 marks)