

**Instructions to candidates**

**Duration:** Two(02) hours

**Number of questions:** Four(04) Essay Questions

**Mark allocation:** 100 mark

Use standard symbols without definition.

Scientific calculators are allowed.

**Answer all questions**

1.

- a. Find the *adjacency matrix* and *incidence matrix* of the following graph. (04 mark)

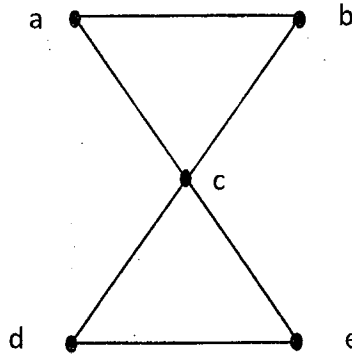

- b. Draw the graph represented by the given adjacency matrix. (03 mark)

$$\begin{bmatrix} 1 & 2 & 0 & 1 \\ 2 & 0 & 3 & 0 \\ 0 & 3 & 1 & 1 \\ 1 & 0 & 1 & 0 \end{bmatrix}$$

- c. Determine whether the following pairs of graphs are *isomorphic* or *not*. **Justify your answer.**

i.

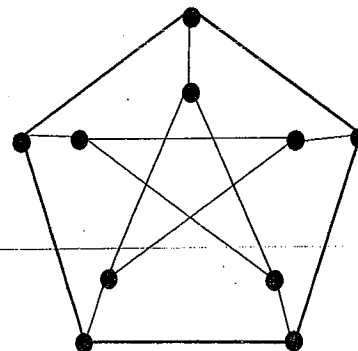
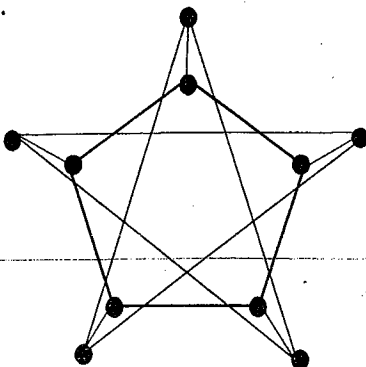

(05 mark)

ii.

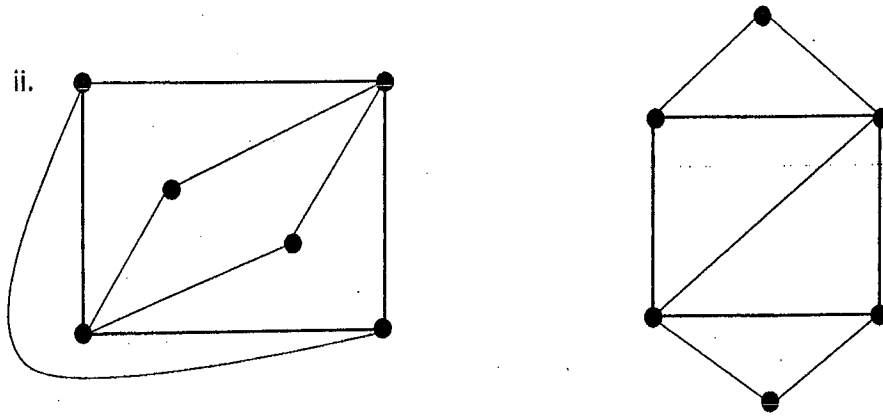

(03 mark)

- d. The following weighted graph represents a network of roads connecting a collection of towns. A travelling salesperson has to visit each town and return to his or her starting point. It is required to choose a route which minimizes the total distance of the round trip. Find a shortest possible round-trip route. (05 mark)

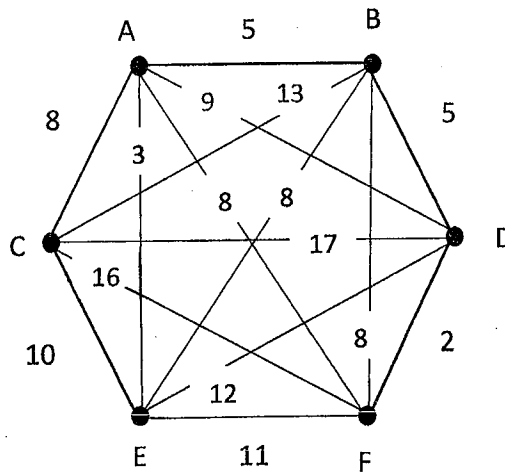

- e. A postman wishes to deliver letters everyday in a network of streets, covering the least possible total distance and return to the post office. He must travel each road in his route, at least one, but should avoid covering too many roads more than once. Find the minimum distance he has to travel. (Where a non-negative numbers associated with each edge that represents the actual distance between corresponding nodes.) (05 mark)

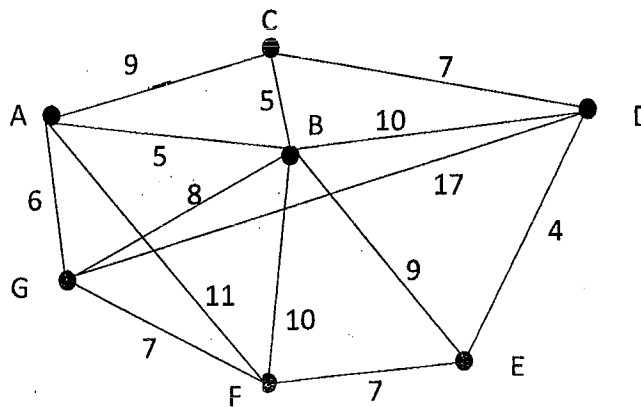

2.

a. Consider the tree with root at  $a$  given below.

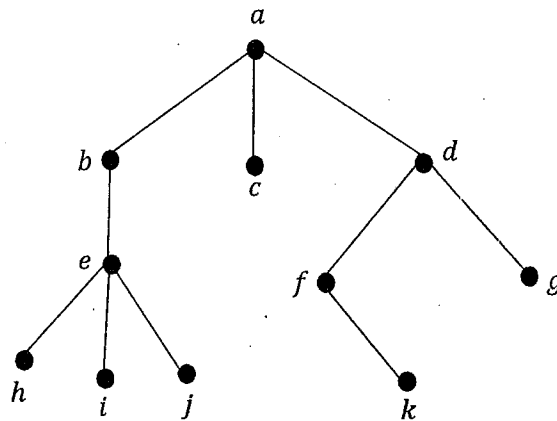

- i. Find the parents of  $c$  and  $f$ . (02 mark)
- ii. Find the children of  $e$  and  $d$ . (02 mark)
- iii. Find the siblings of  $c$  and  $i$ . (02 mark)
- iv. Find the leaves. (02 mark)
- v. What are the levels of  $c$  and  $h$ ? (02 mark)

b. Obtain a *spanning tree* for the graph given below by using;

- i. Depth First Search (DFS) algorithm. (04 mark)
- ii. Breadth First Search (BFS) algorithm. (04 mark)

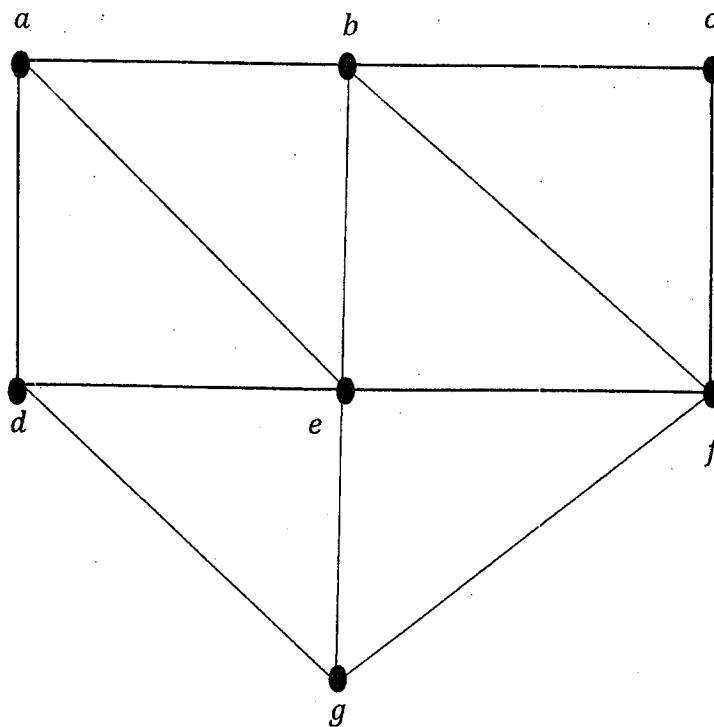

- c. Use **Prim's algorithm** or **Kruskal's algorithm** to find a *minimum spanning tree* for the given weighted graph. (07 mark)

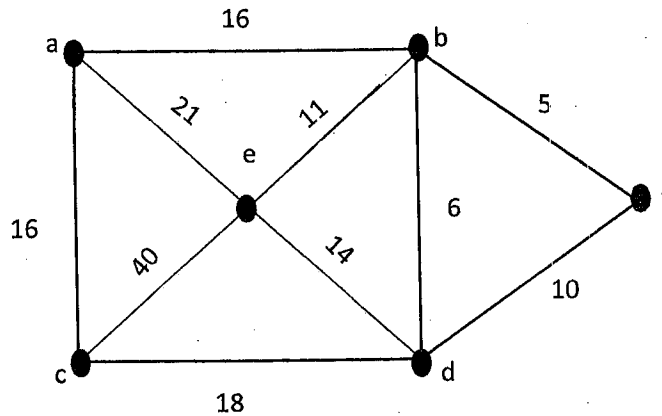

3. a. Define *chromatic number* of a graph. (02 mark)

- b. Planning timetables is one of the most complex and error-prone applications. There are serious problems occurring and these problems are repeating frequently. Therefore, there is a great requirement for an application distributing the courses evenly and without collisions. *Graph vertex coloring method* is one of the most used method to solve these circumstances.

In a typical semester, Department of Computer Science & Technology offers five courses: Cloud Computing (CST 201), Computational Mathematics (CST 202), Basic Electronics (CST 203), Software Engineering (CST 204), and Computer Programming (CST 205). The courses are required to be scheduled at different times in order to avoid conflicts. The problem of determining the minimum number (or a reasonable number) of time slots needed to schedule all the courses subject to the given restrictions.

The list of courses along with the set of potential conflicts are given in below table. In the table, an asterisk indicates those pairs of courses that would cause a timetabling conflict if both were scheduled at the same time.

	CST 201	CST 202	CST 203	CST 204	CST 205
CST 201		*	*	*	
CST 202	*		*	*	*
CST 203	*	*		*	
CST 204	*	*	*		*
CST 205		*		*	

- Create a conflict-free time table of courses by using **vertex coloring method**. (07 mark)

- c. Use **Dijkstra's algorithm** to find the shortest path from source to sink in the following network, where numbers represent actual distance between corresponding nodes.

(08 mark)

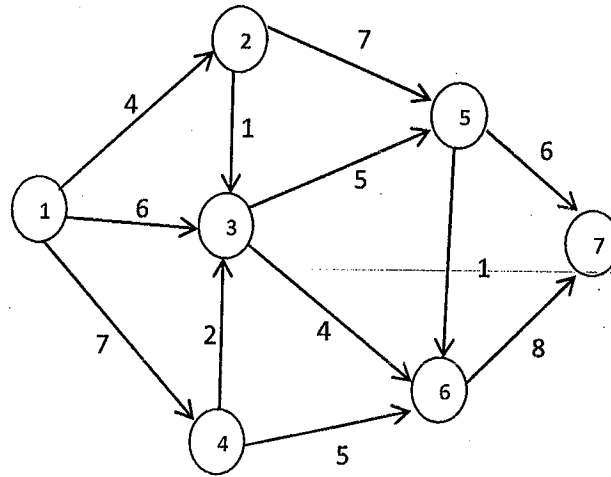

- d. Use **augment path algorithm** to find maximum flow for the following network. Find a cut with capacity equal to this maximal flow. Hence, verify the **maximum flow – minimum cut theorem**.

(08 mark)

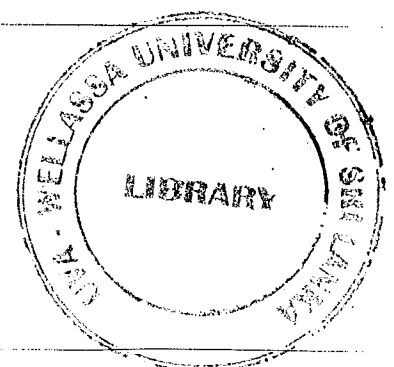
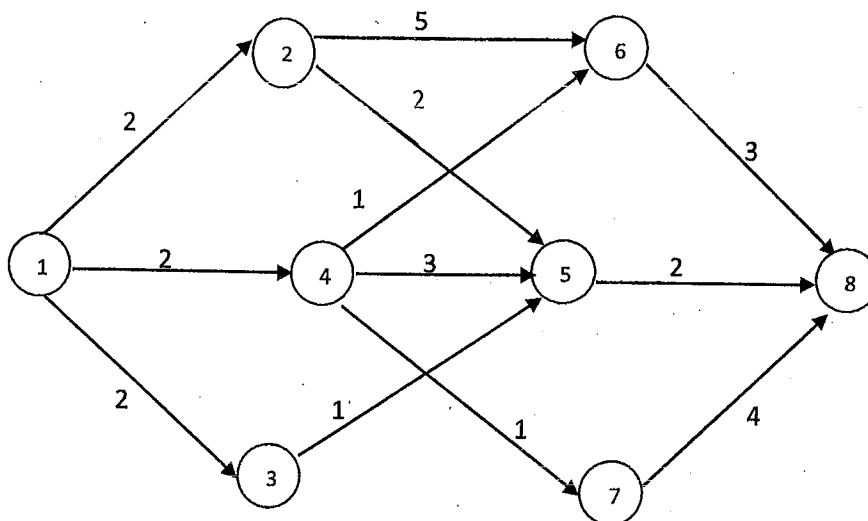

4.

a. Define Boolean algebra. What is the main difference between Boolean algebra and algebra of numbers? (04 mark)

b. Construct a switching circuit to meet the requirements of Boolean expression:

$$A \cdot (A \cdot \bar{B} \cdot C + B \cdot (A + \bar{C})). \quad (04 \text{ mark})$$

e. Determine the Boolean expression for the switching circuit shown in below. (04 mark)

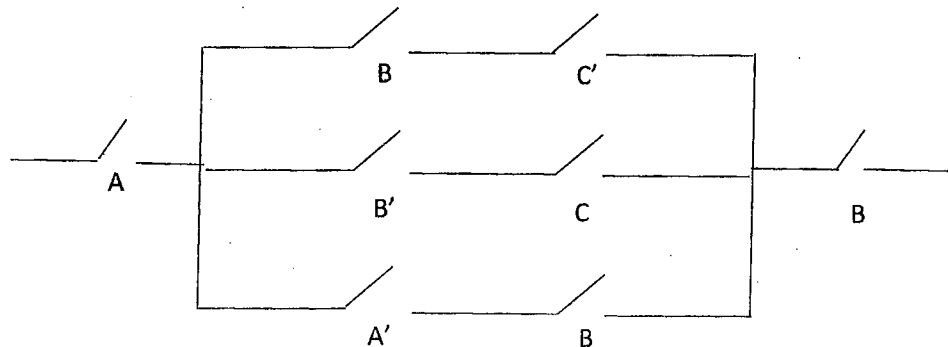

d. Write the Boolean expression corresponding to the following logic circuit. (03 mark)

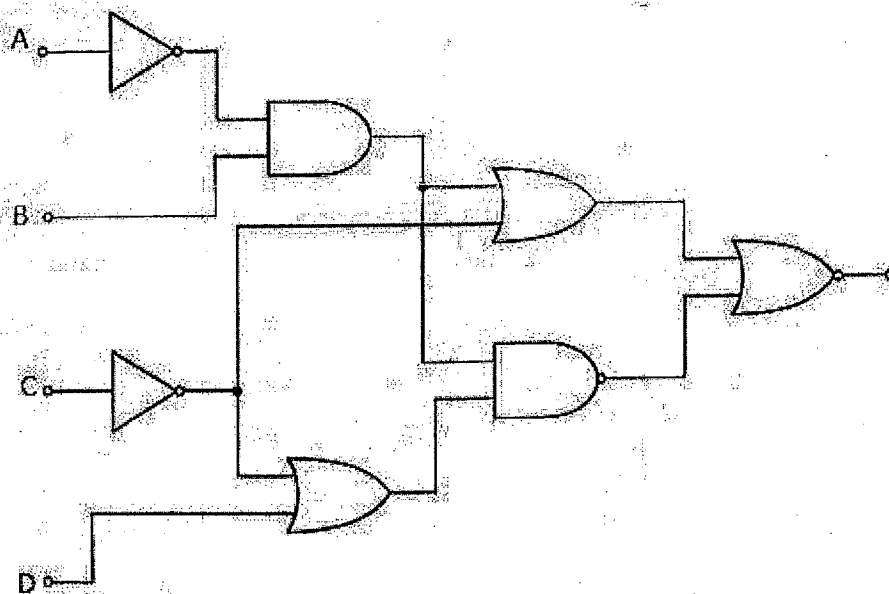

e. Draw Karnaugh map and simplify the following Boolean expressions:

i.  $\bar{A}B\bar{C} + A\bar{B}\bar{C} + \bar{A}\bar{B}C + \bar{A}BC + A\bar{B}C + A\bar{B}\bar{C}$  (05 mark)

ii.  $F(A, B, C, D) = \sum(0, 2, 3, 6, 7, 8, 12)$  (05 mark)