

**Instructions to candidates**

**Duration:** 01 hour

**Number of questions:** 02

**Mark allocation:** 100 mark

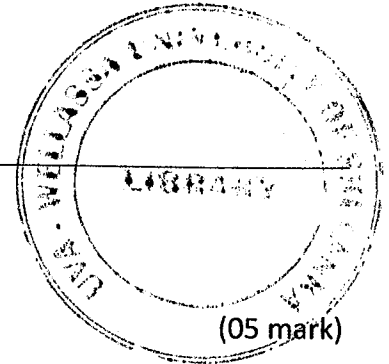

1.

a. State Kirchoff's laws applied to an electrical circuit.

(05 mark)

b.

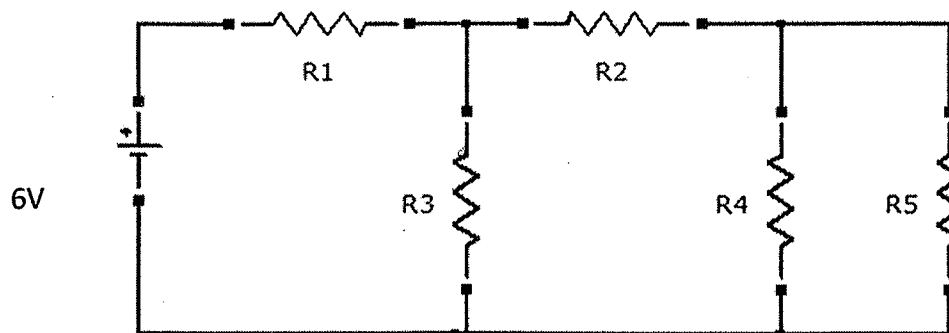

A 6V battery is connected across a resistive network as shown in the figure.

$R_1 = R_2 = 5\Omega$ ,  $R_3 = 20\Omega$ ,  $R_4 = 15\Omega$  and  $R_5 = 10\Omega$ .

Consider the  $10\Omega$  resistor as the load connected to the network, and obtain the Thevenin's equivalent circuit of the network.

(25 mark)

c. Draw the Bridge Rectifier circuit used for full wave rectification and indicate the direction of the current flow through the load at each half cycle.

Draw the input and output wave forms.

(15 mark)

2.

- a. An a.c. generator is supplying a load of 300 kW at a power factor of 0.6. If the power factor is raised to unity, how much power (in kW) the generator can supply for the same kVA rating?

How much more power has been supplied by the generator?

(25 mark)

- b. The primary winding of a single phase transformer is connected to a 230V, 50Hz supply. The secondary winding has 1500 turns. If the maximum value of the flux is 0.002Wb, determine,

- i. Number of turns of the primary winding
- ii. The secondary voltage

(25 mark)

- c. State the losses present in a transformer.

(05 mark)