

UVA WELLASSA UNIVERSITY  
DEPARTMENT OF COMPUTER SCIENCE & TECHNOLOGY  
FACULTY OF SCIENCE AND TECHNOLOGY  
END SEMESTER EXAMINATION - SEMESTER I - 2008/2009

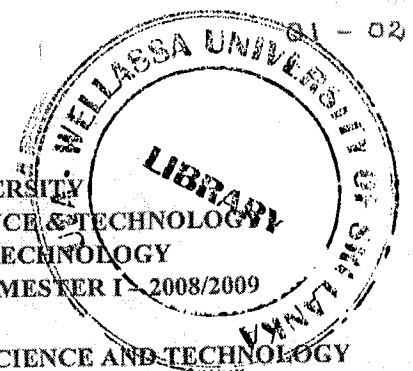

CST102-2 INTRODUCTION TO COMPUTER SCIENCE AND TECHNOLOGY

Time Allowed: TWO HOURS

Answer four (04) Questions including Question 1 and 2

Q1 a. Programs typically go through six phases. The following diagram explains a typical program development environment. Identify the processes and objects labeled from (a) to (h) in the diagram (08)

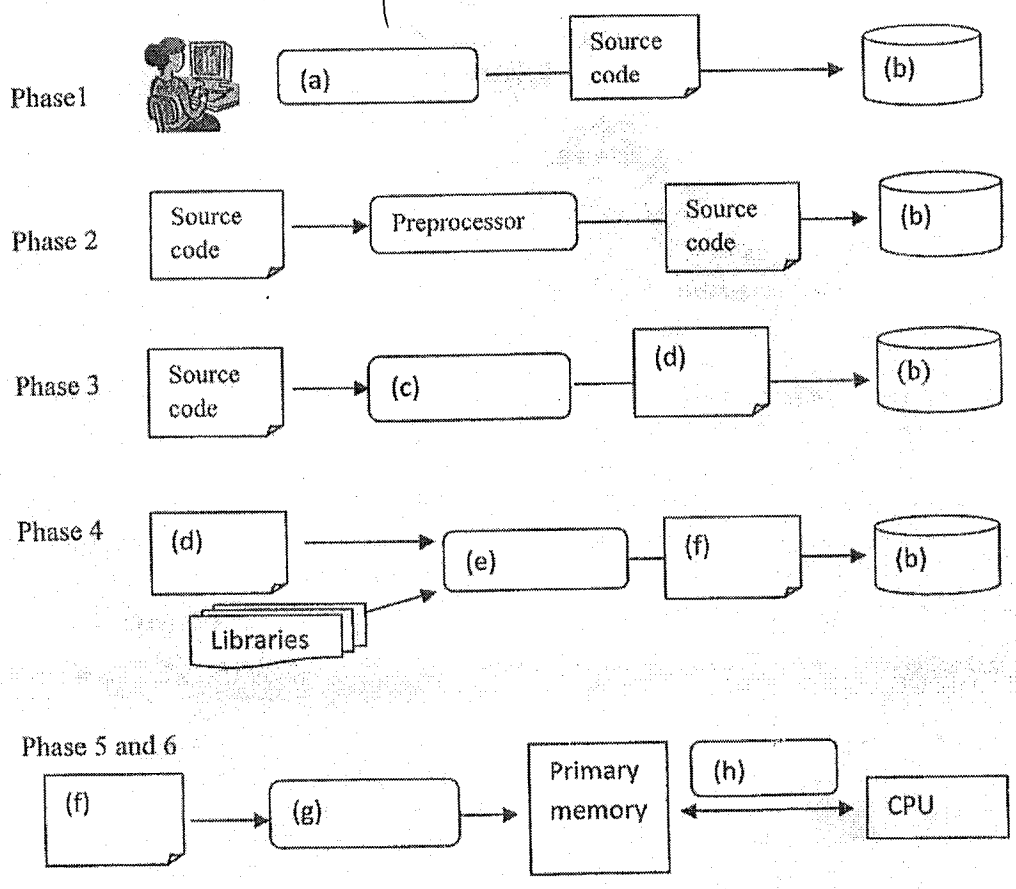

b. Given below is a basic block diagram of a computer.

(12)

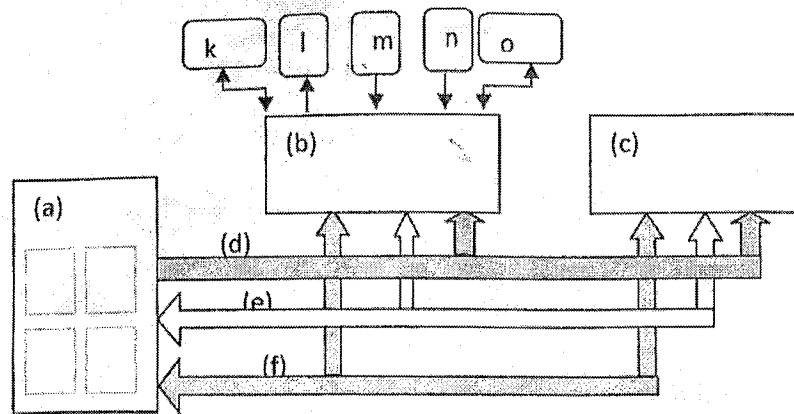

- I. Identify the components labeled from (a) to (f)
- II. What do you think the boxes labeled as k, l, m, n and o represent.

c. Describe two(02) of the following topics briefly but precisely

(12)

- a. Internet and World Wide Web
- b. Adding value to commerce via Internet – *e-commerce*
- c. Cloud computing

Q2 a. Given below is the binary content of a small text file represented in hexadecimal notation. If the file is encoded in ASCII format, write down the content of the file in English letters. The standard ASCII table is attached at the end of the question paper. (Hint: in ASCII format each character is represented by two hexadecimal numbers (1 Byte)).

(28)

57656C6C61737361

b. A data set of 100 integers ranging from -500 to 500 is to be stored in a computer.

- I. If two's complement notation is used to store these integers what's the minimum number of bits to be used to store a single integer?
- II. If the same integers are stored in a computer file separating each integer by a single byte what's the file size in bytes?
- III. If the same integers represented in ASCII format and stored in a text file what is the size of the text file? If an exact answer cannot be calculated justify your answer.

Q3 a. If A, B and C are Boolean variables, prove  $(A+B)(A+C) = A+BC$  (20)

b. There is a car with 4 main control systems namely A, B, C and D. You are asked to design a system to light a warning lamp if any of the following conditions occur.

- A and B are Down
- A, C and D are Down
- B, C and D are Down
- B and D are Down

- I. Draw the truth table for the above system
- II. Derive the logic equation and simplify it
- III. Draw the logic diagram

Q4 a. How can you classify networks based on the size? Give examples for each of them. (20)

b. I. What is the communication media used in each of the following scenario ?

1. Radio broadcast
2. Computer network in a laboratory
3. Bluetooth connection
4. Long distance telephone communication
5. Remote controller
6. Mobile phones
7. TV broadcast

II. Compare and contrast the above communication media.

Q5 A Digital camera when working in its highest performance has a video resolution of 640 x 480 pixels and frame rate of 25 fps (frames per second). The camera can record video in true colour (24 bit). This camera comes with a 256 MB memory card. (20)

- a. Is it possible to record a 16 minute video with this camera? Justify your answer.
- b. The camera records audio with a sample rate of 11000 samples per second using 16 bit samples. If you are to record a video with audio using this camera how long can you record? Justify your answer.

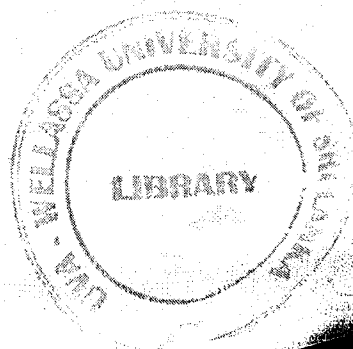
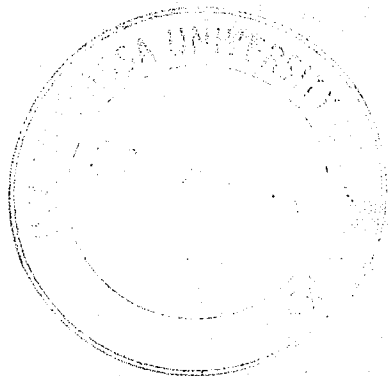

## ASCII Table

ASCII	Decimal	ASCII	Decimal	ASCII	Decimal
null	0	,	44	X	88
start of header	1	-	45	Y	89
start of text	2	.	46	Z	90
end of text	3	/	47	[	91
end of transmission	4	0	48	\	92
enquire	5	1	49	]	93
acknowledge	6	2	50	^	94
bell	7	3	51	_	95
backspace	8	4	52	`	96
horizontal tab	9	5	53	a	97
linefeed	10	6	54	b	98
vertical tab	11	7	55	c	99
form feed	12	8	56	d	100
carriage return	13	9	57	e	101
shift out	14	:	58	f	102
shift in	15	;	59	g	103
data link escape	16	<	60	h	104
device control 1/Xon	17	=	61	i	105
device control 2	18	>	62	j	106
device control 3/Xoff	19	?	63	k	107
device control 4	20	@	64	l	108
negative acknowledge	21	A	65	m	109
synchronous idle	22	B	66	n	110
end of transmission block	23	C	67	o	111
cancel	24	D	68	p	112
end of medium	25	E	69	q	113
end of file/ substitute	26	F	70	r	114
escape	27	G	71	s	115
file separator	28	H	72	t	116
group separator	29	I	73	u	117
record separator	30	J	74	v	118
unit separator	31	K	75	w	119
space	32	L	76	x	120
	33	M	77	y	121
"	34	N	78	z	122
#	35	O	79	{	123
\$	36	P	80		124
%	37	Q	81	}	125
&	38	R	82	~	126
'	39	S	83	DEL	127
(	40	T	84		
)	41	U	85		
*	42	V	86		
	43	W	87		