

All symbols have their usual meaning, unless defined.

Scientific Calculators are allowed.

Duration: 02 hour

Number of questions: 04

Mark allocation: 100 marks

1.

a. Define the viscosity. (4marks)

b. Write four types of fluids and sketch a graph of shear stress against velocity gradient to indicate differences among them. (6marks)

c. If the velocity distribution over a plate is given by $u = \frac{2}{3}y - y^2$ in which u is the velocity in meter per second at a distance y meter above the plate, determine the shear stress at $y=0$ and $y=0.15$ m. Take dynamic viscosity of fluid as 0.831 Nsm^{-2} . (15marks)

2.

a. Calculate the capillary rise in a glass tube of 2.5 mm diameter when immersed vertically in (a) water (b) mercury. Take surface tensions $\sigma = 0.0725 \text{ Nm}^{-1}$ for water and 0.52 Nm^{-1} for mercury in contact with air. The specific gravity for mercury is given as 13.6 and angle of contact = 130° . (15 marks)

b. The right limb of a simple U tube manometer containing mercury is open to the atmosphere while the left limb is connected to a pipe in which a fluid of specific gravity 0.9 is flowing. The center of the pipe is 12 cm below the level of mercury in the right limb. Find the pressure of fluid in the pipe if the difference of mercury level in the two limbs is 20 cm (Figure 01). (10 marks)

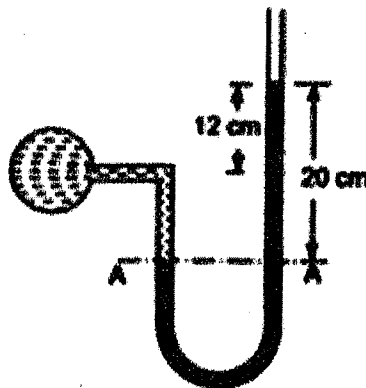

Figure 01



3. For the circuit of figure 02 calculate
- The current drawn from the source (5 marks)
 - The potential difference across each resistor (6 marks)
 - The current through each resistor and (12 marks)
 - The power dissipated by the 5Ω resistor (2 marks)

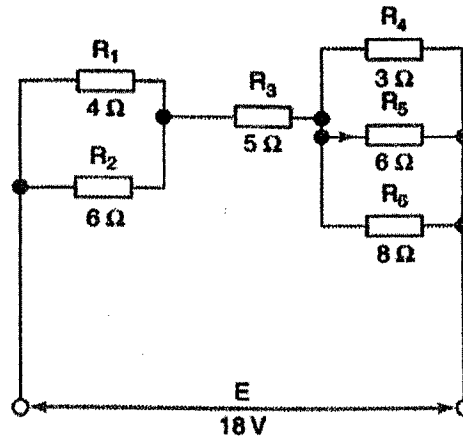

Figure 02

4. a. Use Thevenin's theorem to find the voltage V_{TH} and resistance R_{TH} of the source that drives the load in the circuit shown in the diagram. Hence determine the current through $1\text{ k}\Omega$ resistor (Figure 03).

(10 marks)

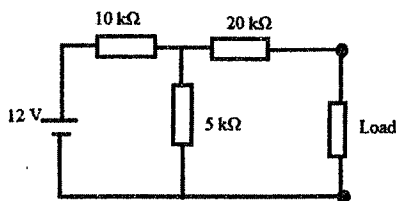

Figure 03

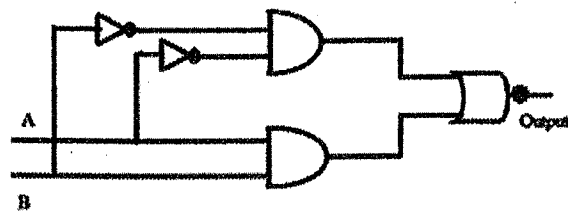

Figure 04

- b. Give the truth table and Boolean expression of the above circuit (Figure 04) and reduce Boolean expression to replace it with a single gate.

(15 marks)